

HD06VCRH 7C

- PIR Sensor for max 12M Height.
- With Zhaga Book 18 Receptacle.
- Bi-level Dimmable, Daylight Priority.
- Remote Control.

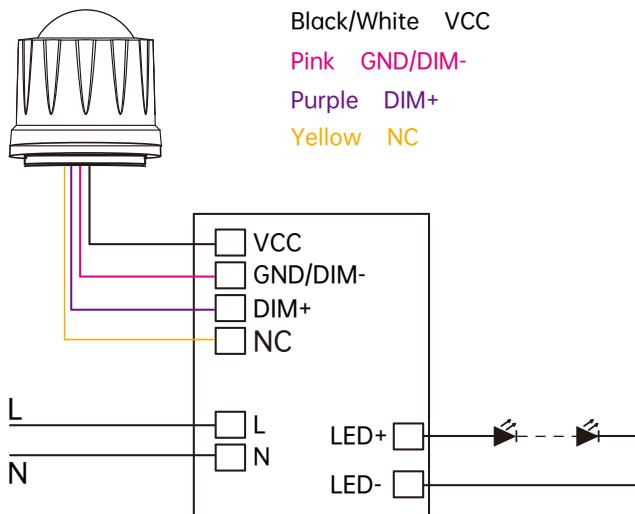

Wiring Diagram



Detection Patterns

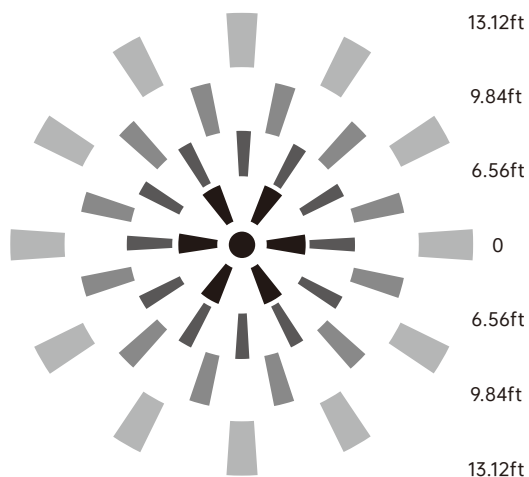

Mounting Height
 ≤12m Ceiling Mounted

Detection Range
 Radius, 2-4m/6.58-13.12ft Ceiling Mounted

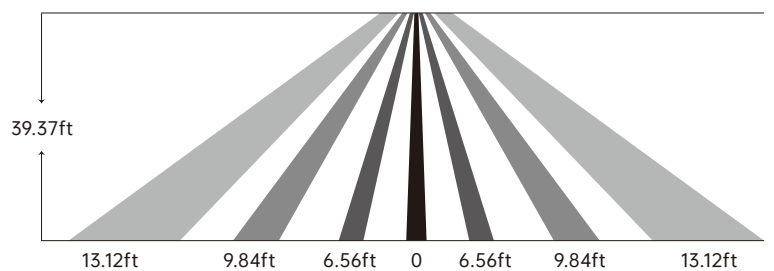

Parameters

Model NO.		HD06VCRH 7C
SENSOR PARAMETER	Daylight Priority Function	Daylight priority function works when daylight threshold per set as 20Lux/80Lux/50Lux/30Lux, standby period as/+∞ and standby dimming level as 10%/20%/30%
	Detection Area	25%/50%/75%/100%
	Daylight Threshold	Disable/400Lux/350Lux/300Lux/250Lux/200Lux/120Lux/80Lux/50Lux/30Lux/10Lux/2Lux
	Standby Dimming Level	10%/20%/30%/50%
	Standby Period	0s/10s/30s/1min/5min/10min/30min/60min/+∞
	Holdtime	5s/30s/1min/3min/5min/10min/20min/30min
	Installation Height	Max.12m/39.37ft Ceiling Mounted
	Detection Distance	Radius,2-4m/6.58-13.12ft Ceiling Mounted
	Warranty	3 Years
INPUT	Input Range	10.5-15V DC
	Connection	zhaga
OUTPUT	Signal	DIM 0-10V
	Stand-by Power	<15mA Power Consumption
ENVIRONMENT	Storage Temp	-20°C~+60°C
CERTIFICATE & STANDARDS	Environmental Requirements	In accordance with CE ROHS
	IP Rating	IP65

Mechanical structure

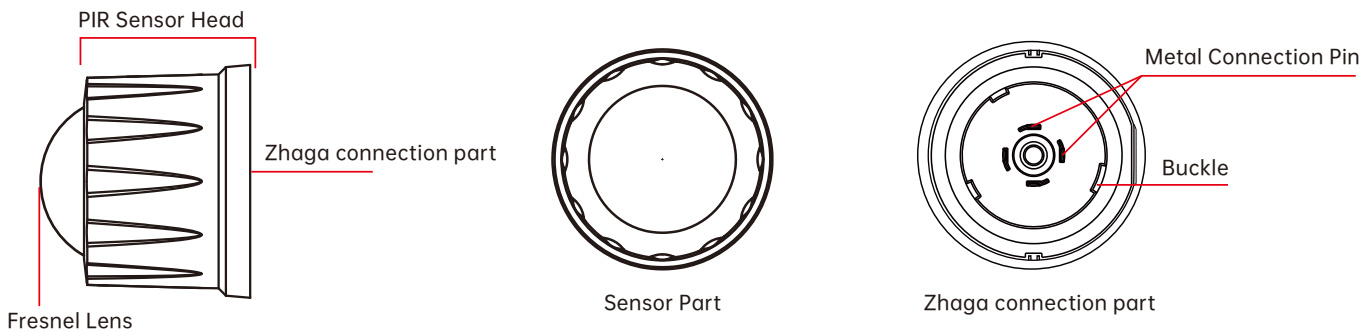

Installation



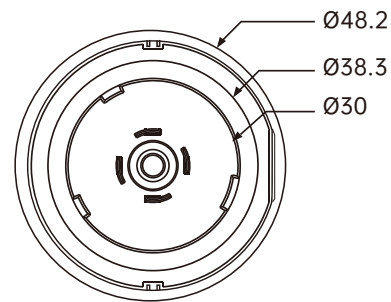
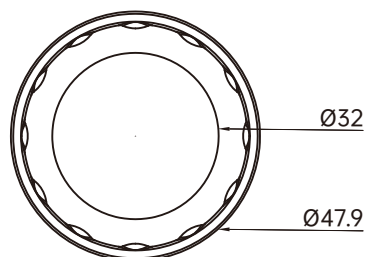
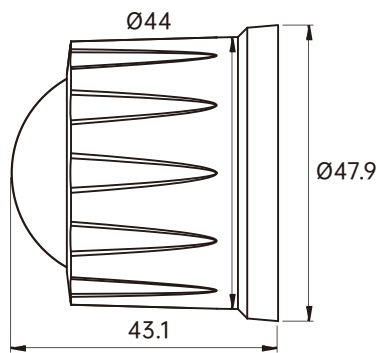

Cap

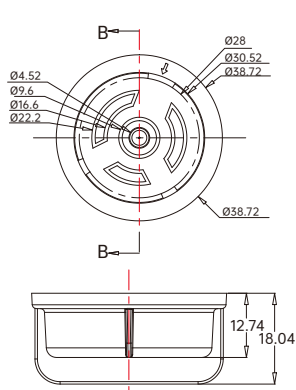

Module

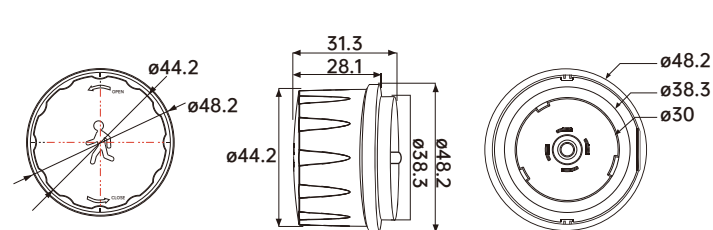

Receptacle

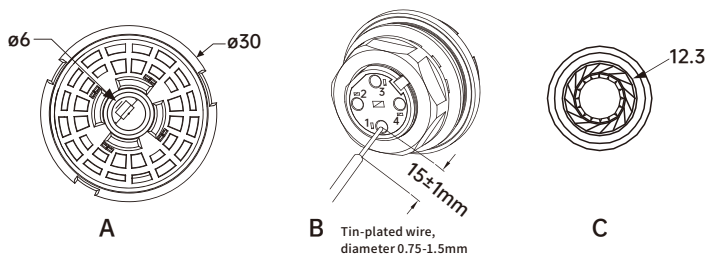

Components

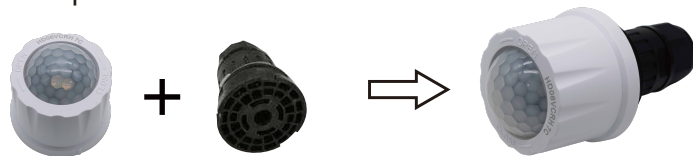

Group 1. Receptacle with the functional module.



Group 2. Receptacle with the cap, no function.

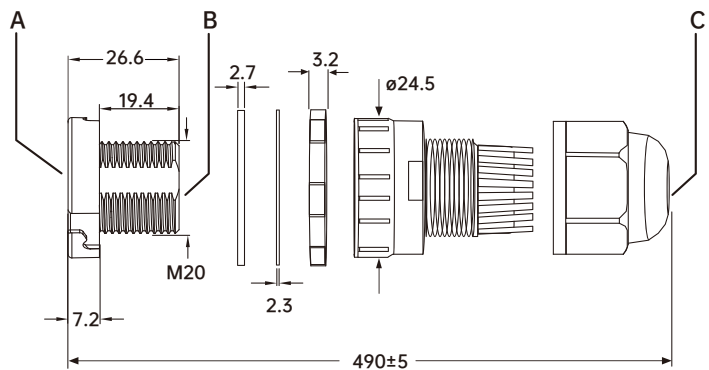



Attention

1. The sensor should be installed by qualified electrician and ensure power is OFF before installation.
2. Please read the instruction carefully before using the product and keep it well for other users to read any time.
3. We reserve the right to modify any incorrect text, image and technical parameters.
4. Any unauthorized modification is forbidden. Otherwise all guarantees will be immediately invalid.
5. Product could be optimized without prior notice.

Application Notes

1. Suitable for indoor application, half/completely outdoor environment conditions might trigger the sensor.
2. Suitable for ceiling mount installation, adjust sensitivity properly if it's installed on side-wall because it gets more sensitive.
3. PIR sensor can't be placed inside any material, fresnel lens must completely exposed in air.
4. Fresnel lens of the PIR sensor must be lower than light fixture.
5. Not suitable environment if there's sudden changed temperature of airflow for PIR sensor.
6. Not suitable environment if there's shelves blocking between the sensor and presence area.
7. Detection area options may NOT working obviously because it works depends on fresnel lens, it's physically defined.
8. Detection distance performance works better when moving parallelly than moving towards to the sensor.
9. Daylight testing delivered in bright day without shadow or specially designed lampshade or lens.
10. Dimming performance differs when connected to different drivers; If the driver can't completely turn OFF, sensor can't either.
11. Input power voltage must be stable with float less than 10%.
12. The first time powered ON sensor, light will be ON 100% for about 45S then dims to standby level or OFF.
13. Distance detection is delivered by testing person about 165cm in open area as reference, the result differs by size and speed of moving objects, mounting height and real-life situation.